

THE SUREFIRE NO-HASSLE GUARANTEE

We'll do what it takes to keep your SureFire gear running smoothly. SureFire warrants that if you — our customer — purchase one of our products, and we determine that it is defective in material and/or workmanship during your lifetime, we will repair or replace it — no hassle!

Our warranty does not cover consumables or normal wear-and-tear — things like batteries draining, headbands and headpads wearing out, ink cartridges running out, and switches wearing out — or damage resulting from abuse, alterations, unauthorized repairs, or use contrary to SureFire's user manuals.

Should you need a replacement product, SureFire reserves the right to replace an obsolete product with a current production, like model. In the event that any issue with a SureFire product is not covered under this warranty SureFire can arrange to have the product repaired for a reasonable fee.

STANDARD DISCLAIMER

Except as specified above or prohibited by applicable law: all express or implied conditions and warranties, including, without limitation, any implied warranty or condition of merchantability or fitness for a particular purpose, or accuracy of any informational content, are hereby excluded and disclaimed by SureFire; and in no event will SureFire be liable for any special, direct, indirect, consequential, incidental or punitive damages howsoever arising and regardless of the theory of liability, even if advised of the possibility of such damages. Products, prices, availability, specifications, and offers are subject to change or cancellation at any time without notice.

WARRANTY CLAIMS

For claims, contact Customer Service at 714-545-9444 to obtain a Return Merchandise Authorization number (RMA#). Then package the unit carefully and send to (no CODs):

SureFire, LLC.
Repairs Department, RMA# _____
17680 Newhope Street, Suite B
Fountain Valley, CA 92708

SureFire will pay any reasonable shipping costs to return the unit to you.



Revision C 10-2020
71-01-1045
6PX TACTICAL & G2X TACTICAL

18300 MT. BALDY CIRCLE
FOUNTAIN VALLEY, CA 92708-6122
SUREFIRE.COM

Patents: RE40125, D639478, D644775



6PX™ TACTICAL / G2X™ TACTICAL SINGLE-OUTPUT LED FLASHLIGHTS

6PX-C-BK
G2X-C-BK

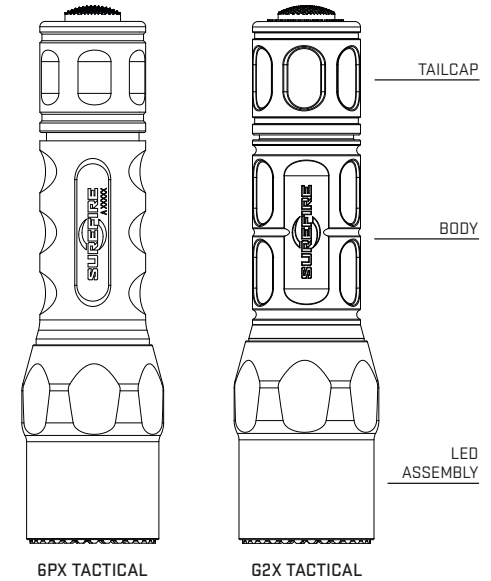

	6PX	G2X
OUTPUT	600 lumens	600 lumens
RUNTIME	1.5 hours	1.5 hours
PEAK BEAM INTENSITY	8,700 candela	8,700 candela
BEAM DISTANCE	187 meters	187 meters
WEIGHT (w/batteries)	5.2 oz (147 g)	4.4 oz (125 g)
LENGTH	5.2 in (13.2 cm)	5.2 in (13.2 cm)
BEZEL DIAMETER	1.25 in (3.175 cm)	1.25 in (3.175 cm)

All performance claims tested to ANSI/NEMA FL1-2019 Standard.

USER MANUAL

6PX™ TACTICAL / G2X™ TACTICAL

LOCKOUT TAILCAP

Most SureFire illumination tools feature a lockout tailcap, which prevents accidental activation during storage or transport. The tailcap may need to be enabled prior to light operation.

To enable, rotate tailcap clockwise until pressing pushbutton activates light.

To lock out tailcap, rotate counterclockwise until light will not activate when pushbutton is pressed.

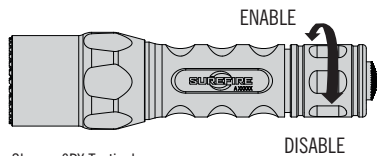

Shown: 6PX Tactical

LIGHT OPERATION

The 6PX and G2X are equipped with a click-type tailcap pushbutton switch. For momentary-on activation, press the push button partially. For constant-on activation, press the pushbutton fully. Release pushbutton or click again to deactivate.

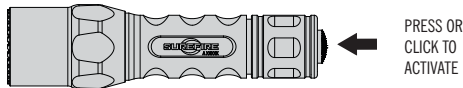

Shown: 6PX Tactical

BATTERY INSTALLATION / REPLACEMENT

⚠ WARNING

Use of substandard batteries can cause injury or property damage. Visit www.surefire.com/batterysafety.

The 6PX and G2X ships with two preloaded batteries. To load or replace batteries:

1. Unscrew tailcap counterclockwise and remove.
2. Remove old batteries and dispose of properly.

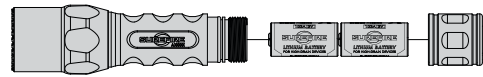

Shown: 6PX Tactical

3. Insert new 123A lithium batteries with positive (+) terminals oriented forward.
4. Replace tailcap by screwing on clockwise. Press pushbutton (with tailcap enabled) to test.

Note: Never mix old and new batteries; always replace all batteries at same time.

⚠ BATTERY INFORMATION & WARNING

Before replacing batteries, read the enclosed BATTERY INFORMATION/WARNING insert in your original packaging. For additional battery safety, handling, and product information, visit www.surefire.com/batteries.

MAINTENANCE

Use a clean, dry cloth to wipe off body and window. Periodically clean and lubricate threads and O-rings using a thin coat of non-migrating, silicone-based lubricants. Avoid using petroleum-based lubricants that can damage O-rings. For additional tips on maintaining your SureFire illumination tool, visit www.surefire.com/faqs-maintenance.

ACCESSORIES

SureFire makes a full line of accessories for most of its illumination tools. For a complete listing, visit www.surefire.com/partsaccessories.